



VESDA[®] LaserSCANNER[™]

INSTALLATION MANUAL

VLS Models

- VLS-200
- VLS-204
- VLS-214
- VLS-300
- VLS-304
- VLS-314
- VLS-600
- VLS-700

October 2003

Version 1.2

Publication history

Release 1.2 October, 2003

Copyright Information

This document may not be reproduced, in whole or in part, by any means without the prior express written permission of the copyright owner. Copyright © 2003 Vision Fire & Security Pty Ltd
A.C.N. 008 009 514

Disclaimer

The manufacturer reserves the right to change designs or specifications without obligation and without further notice. VESDA, LaserTEKNIC, LaserPLUS, LaserSCANNER, LaserCOMPACT, VESDAnet, VESDALink, ASPIRE, AutoLearn, VSM, VConfig, InfoWORKS, PROACTIV and PRECISION are trademarks used under licence by the distributor.

Codes and Standards Information

Vision Products strongly recommends that this guide is read in conjunction with the appropriate local codes and standards for smoke detection systems and electrical connections. This guide contains generic information and some sections may not comply fully with all local codes and standards. In these cases, the local codes and standards must take precedence.

FCC Compliance Statement

This equipment has been tested and found to comply with the limits for a Class B digital device, pursuant to part 15 of the FCC Rules. These limits are designed to provide reasonable protection against harmful interference in a residential installation. This equipment generates, uses and can radiate radio frequency energy and, if not installed and used in accordance with the instruction, may cause harmful interference to radio communications. However, there is no guarantee that interference will not occur in a particular installation. If this equipment does cause harmful interference to radio or television reception, the user is encouraged to try to correct the interference by one or more of the following measures:

- Reorientate or relocate the receiving antenna
- Increase the separation between the equipment and receiver
- Connect the equipment to a power outlet which is on a different power circuit from which the receiver is connected
- Consult the dealer or an experienced radio/television technician for help

FM 3611 Hazardous Approval Warning

Exposure of some chemicals may degrade the sealing of relays used on the detector. Relays used on the detector are marked "TX2-5V" or "G6S-2-5V" or "EC2-5NU".

Approvals and Standards

The product complies with the following standards.

AS 1603.8	FCC Class B
AS/NZS 3548	AS2211
EN50081-1	21 CFR 1010.2
EN50130-4	21 CFR 1010.3
	EN 60950

Safety Label

The LaserSCANNER incorporates a Laser device and is classified as a Class 1 Laser product that complies with FDA Regulations 21 CFR 1040.10 and 1040.11. The laser is housed in a sealed Detector chamber and contains no serviceable parts. This laser emits invisible light and can be hazardous if viewed with the naked eye. **Under no circumstances should the Detector Chamber be opened.** There is a safety label on the Detector Chamber as shown below.



Figure 1 The Laser Warning Label

Contents

1.	Introduction	2
2.	Cabling Requirements	3
2.1	Power Cables.....	3
2.2	Power Consumption	3
2.3	Data Cables	3
3.	LaserSCANNER Specifications	4
4.	LaserSCANNER Dimensions	5
5.	Battery Backup Calculations	7
6.	Installation	8
6.1	Check Procedure Before Installation	8
6.2	Removal of Front Cover.....	9
	Component Location inside Detector Enclosure	10
6.4	Display and Programmer Module Orientation	10
6.5	Removal of Metal Knockout Holes for Cable Entry	11
6.6	Exhaust Port Options	11
6.7	Securing the Mounting Bracket.....	12
6.8	Attaching the Detector onto the Bracket.....	12
6.9	Connecting the Air Sampling Pipe	13
6.10	Cabling Using Glands and Conduits	13
6.10.1	Using Glands	13
6.10.2	Using Conduits	13
6.11	Termination Card Details.....	14
6.12	Procedure to Terminate Wires to the Termination Card	14
6.13	Terminating the Power Wires to the Termination Card	15
6.14	Connecting the VESDAnet Wires to the Termination Card (If required)	15
6.15	Terminating the Relay Wires to the Termination Card	16
6.16	Closing Up the LaserSCANNER	18
6.17	Pipe Bonding Check	18
7.	Power Up	19
7.1	Power Up the System	19
8.	Preliminary System Checks	20
8.1	Logging On to the System	20
8.2	VESDAnet Communication Check	20
8.3	Normalise the Air Flow and Clearing Air Flow Faults	21
8.4	Basic Pass/Fail Smoke Test	22
9.	Installation Checklist	23
10.	VESDA Product Warranty Conditions	24

1. Introduction

Scope of this Manual

This manual is intended for installation technicians to be able to install, perform basic power and preliminary device checks for the LaserSCANNER detector. It does not cover information for commissioning. All VESDA equipment is to be commissioned by personnel who have attended a VESDA accreditation course.

Use the checklist in Section 9 to verify that the installation has been correctly completed. Fill out the details in the checklist sheet for the site and submit it to the appropriate personnel.

CAUTION

- **The Detector must only be installed by VESDA accredited personnel.**
 - **The performance of the system depends on the pipe network designed for the site. Any alteration to the pipe network may alter the performance of the system. The ASPIRE™ design tool is to be used to verify the suitability of any pipe network design and subsequent alterations. ASPIRE™ is available from your distributor or local Vision office.**
 - **The IP rating for the LaserSCANNER is IP 30. This rating indicates the device is not to be installed where there is the possibility of any water or liquid falling onto the device.**
-

WARNING

- **It is strongly recommended that the mounting bracket be used during installation.**
 - **The chassis assembly and Central Processor Card should NOT TO BE REMOVED or disassembled during installation.**
 - **Follow the installation procedure outlined in this manual.**
-

2. Cabling Requirements

The terminals on the termination card in the LaserSCANNER will accept wire sizes up to 2.5sq mm (12 AWG).

2.1 Power Cables

Use the power ratings for the detector and the modules to determine the required wire sizes. Refer to the table below for power ratings.

2.2 Power Consumption

The power requirements for the detector to operate are as follows:-

Operating voltage: 18VDC to 30VDC

	Power Consumption (W) @ 24VDC		Current Consumption (mA) @ 24VDC	
	Quiescent	With Alarm	Quiescent	With Alarm
LaserSCANNER with Blank Plates @ 3000rpm	5.8	7.4	240	310
LaserSCANNER with Blank Plates @ 3500rpm	6.7	8.4	280	350
LaserSCANNER with Blank Plates @ 4000rpm	8.4	10.1	350	420
LaserSCANNER with Blank Plates @ 4200rpm	9.6	11.3	400	470
Programmer Module	0.6 (Backlight Off)	2.2 (Backlight On)	20 (Backlight Off)	80 (Backlight On)
Display Module Only	1.6	2.2	60	80

Table 1 Power and Current Consumption for LaserSCANNER Detector and Modules

2.3 Data Cables

The recommended RS 485 data cable for interconnecting to other detector units on the VESDAnet loop is Belden 9841 (or equivalent). The cable characteristics are as follows:-

- 24 AWG, Twisted pair, Shielded, 120 ohms impedance

The maximum specified length for the RS485 cable between any two devices on VESDAnet is 1300m (4000ft).

3. LaserSCANNER Specifications

Supply Voltage	18 to 30VDC	
Power Consumption	See table 1, page 2	
Dimensions (WHD)	350mm x 225mm x 125mm (13.8in x 8.9in x 4.9in)	
Weight	4.0kg (9lbs) including Display and Programmer module	
Operating Temperature	Detector Ambient: 0° to 39°C (32°F to 103°F) Sampled Air: -20° to 60°C (-4° to 140°F) Humidity: 10-95% RH, non-condensing	
Sampling Pipe Network	Aggregate pipe length: 200m (650ft) Pipe Modelling Design Tool: ASPIRE™	
Pipe Size	Internal Diameter: 15-21mm (9/16 – 7/8in) External Diameter: 25mm (1in) (25mm to 1inch adaptor supplied for USA market)	
Relays	7 or 12 Relays option. Contacts rated 2A @ 30VDC. Programmable to energised or de-energised states.	
Scan Sector Delay	Min 8 seconds, max 15 seconds	
Scan Threshold Delay	Min 0 seconds, max 10 seconds	
Relays Default Configuration	7 Relays:	Alert, Action, Fire 1, Fire 2, Maintenance, Urgent Fault and Isolate. (7 x NO/NC contacts)
	12 Relays:	Alert, Action, Fire 1, Fire 2, Maintenance, Urgent Fault and Isolate, First Alarm Sector 1 to 4 and Scan. (10 x NO, 2 x NO/NC contacts)
IP Rating	IP30	
Cable Access	8 x 25mm (1in) knockouts in various positions.	
Cable Termination	Screw terminal blocks (0.2-2.5sq mm, 30-12 AWG)	
Sensitivity Range	0.005 to 20.00% obs/m (0.0015 to 6.25% obs/ft)	
Threshold Setting Range	Alert: 0.005 – 1.990% obs/m (0.0015 - 0.6218% obs/ft) Action: 0.010 – 1.995% obs/m (0.0031 - 0.6234% obs/ft) Fire 1: 0.015 – 2.00% obs/m (0.0046 – 0.625% obs/ft) Fire 2: 0.020 – 20% obs/m (0.0062 – 6.25% obs/ft)** ** Limited to 12% obs/m (4% obs/ft) in UL mode	
Key Software Features	Event log: Up to 18,000 events stored on FIFO basis. AutoLearn: Minimum 15 minutes. Maximum 15 days, 23hrs, 59 minutes. Recommended minimum period 14 days. During AutoLearn thresholds are NOT changed from pre-set values. Referencing: Compensation for external ambient conditions. Four Alarm Levels per Sector: Alert, Action, Fire 1 and Fire 2. Two Fault Warning Levels: Maintenance and Urgent fault. Maintenance Aids: Filter and flow monitoring. Event reporting via VESDAnet or event log. Auto Scan and Thresholds Setting: Detector selects the appropriate scan threshold automatically.	

4. LaserSCANNER Dimensions

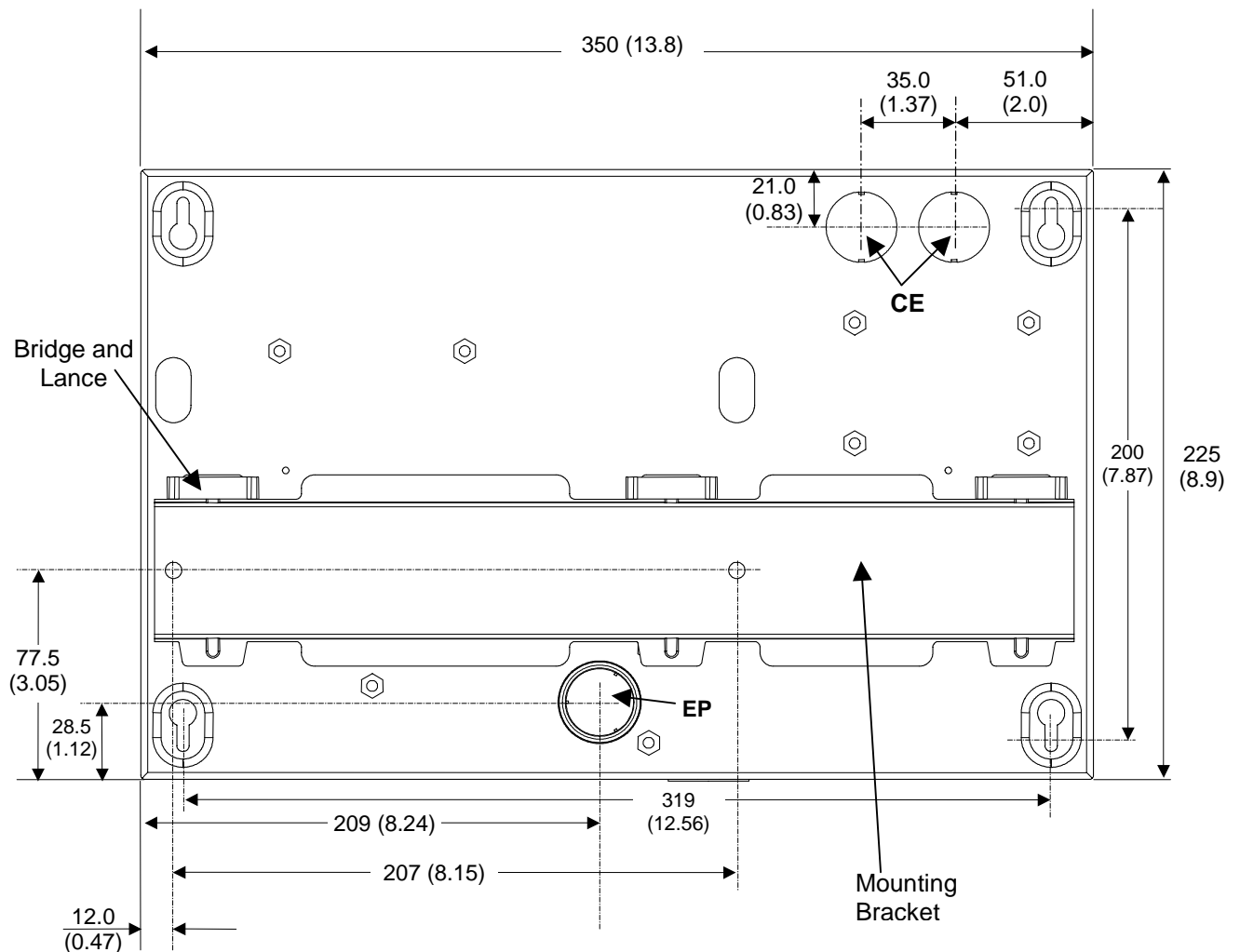

CE = Cable Entry Ports (25.4mm, 1.0in Ø)
EP = Exhaust Air Port

*Figure 1 Dimensions in mm (in) of LaserSCANNER with Mounting Bracket
 (Rear View, Normal Orientation)*

Note: Remove the centre pages of this manual for installation template. We strongly recommend the use of this mounting bracket.

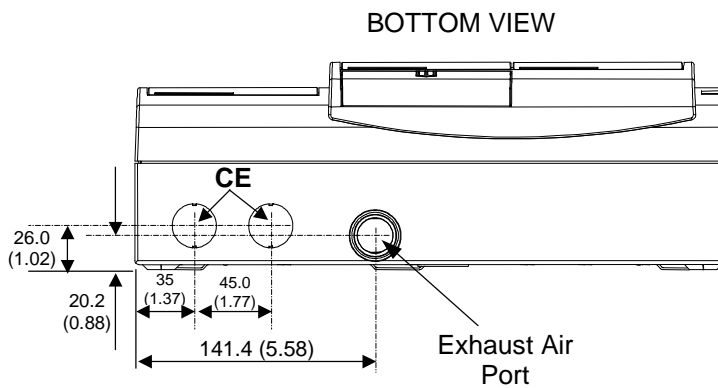
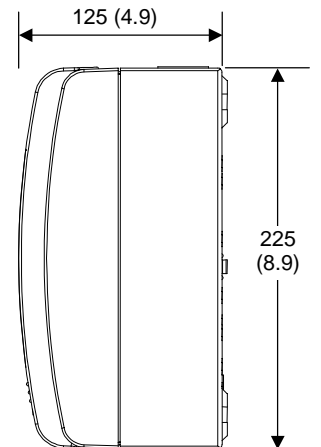
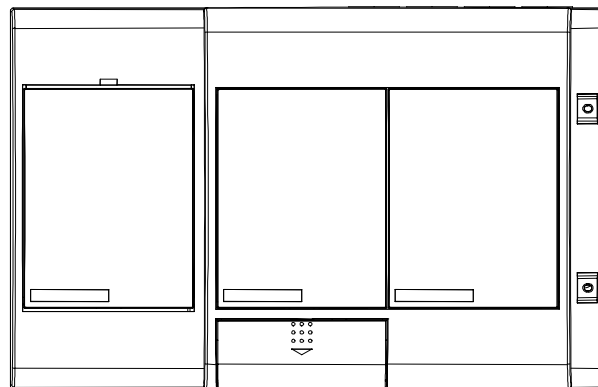
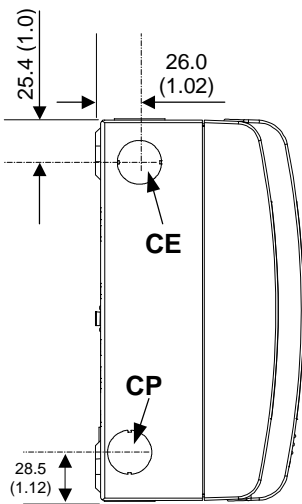
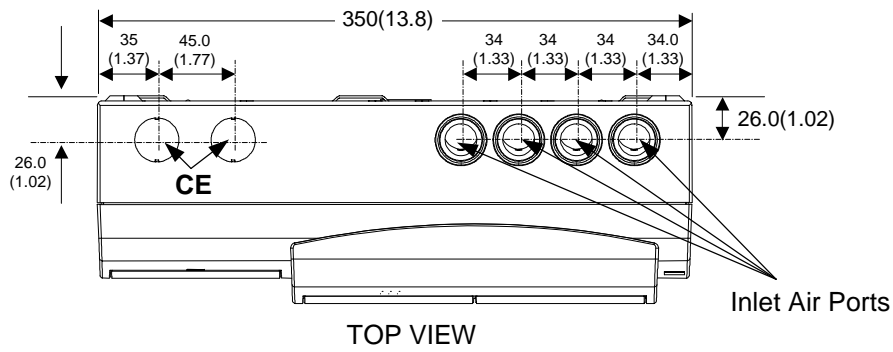

CE = Cable Entry Port (25.4mm, 1.0in Ø)
CP = Exhaust Pipe Outlet Option or Cable Entry Port

Figure 2 Dimensions in mm (in) for the LaserSCANNER

5. Battery Backup Calculations

The nominal supply voltage is **24 VDC**. Use Table 2 to calculate and to determine the battery backup requirements for your VESDA system. Refer to Table 1, page 3 for power consumption details.

EQUIPMENT	NORMAL LOAD @ 24 V DC			FULL ALARM LOAD @ 24 VDC		
	LOAD (mA)	QTY	TOTAL (ma)	LOAD (mA)	QTY	TOTAL (ma)
LaserSCANNER (No display & programmer)						
Display Module						
Programmer Module						
Remote Display						
Other 24V loads						
	TOTAL (mA)		<input type="text"/>	TOTAL (mA)		<input type="text"/>
		X	<input type="text"/>		X	<input type="text"/>
	STANDBY HOURS		<input type="text"/>	ALARM HOURS		<input type="text"/>
		=	<input type="text"/>		X 1.06	<input type="text"/>
STANDBY CAPACITY (mAhr)			<input type="text"/>	ALARM CAPACITY (mAhr)		<input type="text"/>
				TOTAL CAPACITY = STANDBY + ALARM (mAhr)		<input type="text"/>
				DIVIDE BY 1000		<input type="text"/>
				MULTIPLY BY BATTERY FACTOR 1.25		<input style="border: 2px solid black;" type="text" value="Ahr"/>

Table 2 Calculations to Determine the Battery Backup Requirements

6. Installation

6.1 Check Procedure Before Installation

- Do not install your LaserSCANNER if there are any signs of shipping damage to the product. Inform your distributor if there is any damage.
- Check the model of the LaserSCANNER is correct as per the design specifications for the site. Refer to the model number located on the product and approvals label attached at the bottom of the detector.
- Identify the location where the detector is to be mounted. The LaserSCANNER can be mounted on a wall or a suitable secure surface. There are two allowable mounting positions for the LaserSCANNER as shown in Figure 3.
 - Normal Orientation:** Mounting the detector with the **inlet air ports on the top right hand side** of the box and the exhaust air port at the bottom.
 - Inverted Orientation:** Mounting the detector with the **inlet air ports at the bottom left hand side** of the box and the exhaust air port on the top.
- Verify that the selected mounting location is suitable to fit the detector by test fitting the LaserSCANNER onto the actual mounting position or use the drilling template supplied with this manual. Ensure there is 150mm of clear space around the air inlet, exhaust and cable entry ports to allow for pipe and cable entry.
- Verify that the cable entry points and the sampling air pipes are at its correct locations.
- Determine the type of fasteners required for attaching the mounting bracket onto the mounting surface. The size of the mounting holes on the mounting bracket is 6mm (15/64in).

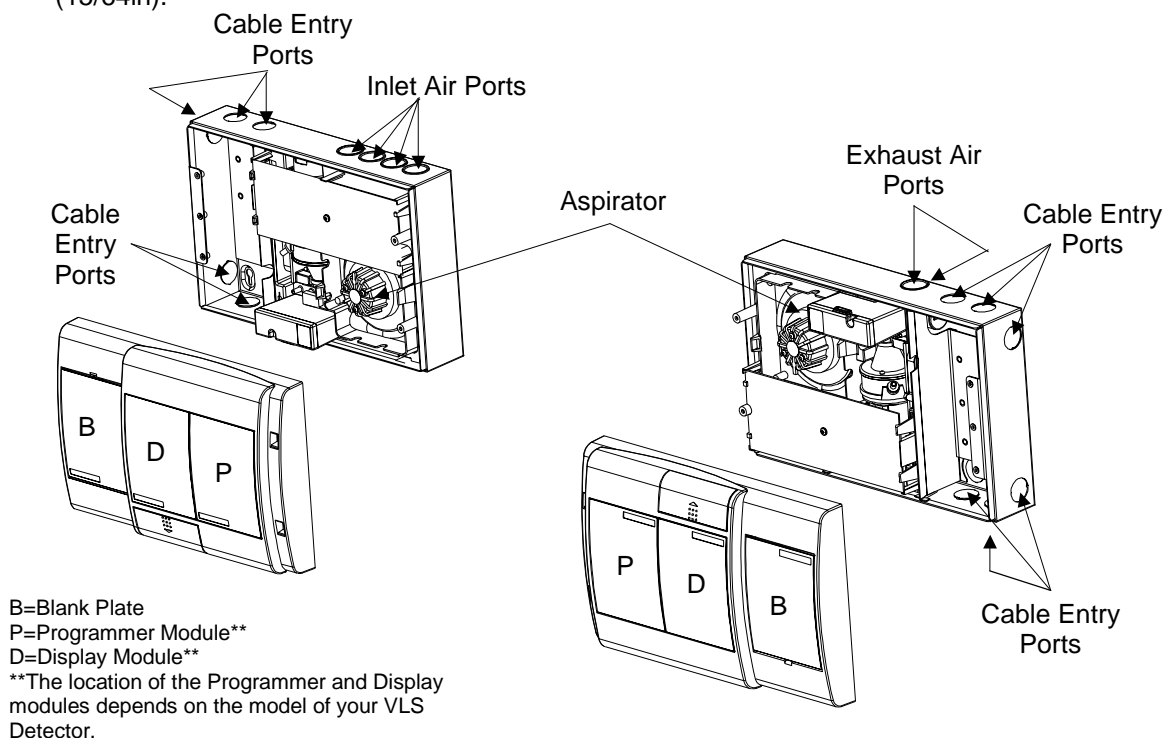

Note: For LaserSCANNER detectors mounted in the *Inverted Orientation* position, the display and/or programmer modules have to be rotated 180°. Refer to Section 6.4 for procedure to rotate the modules. The position of the Programmer and Display modules can be interchanged.

Figure 3 LaserSCANNER Orientation, Normal (left), Inverted (right)

6.2 Removal of Front Cover

- (a) Insert a 4mm x 1mm flat blade screwdriver (A) into notch. Refer to Figure 4.
- (b) Gently open the blank plate (B) with the screwdriver.
- (c) Lift out the two screw covers (C) with a flat blade screwdriver.
- (d) Use a Philips head screwdriver and remove the four retaining screws (D). Screws are captive and are retained within the front cover. Refer to Figure 4.
- (e) When the front cover is opened, there are two plastic straps joining the cover to the enclosure.
- (f) If the front cover is to be separated from the enclosure do the following:-
 - i) On the rear of the front cover or on the enclosure side, twist the plastic strap 90° and slip strap out through slot.
 - ii) Locate the cable loom that connects the central processor card to the back of a display or programmer module that is located on the front cover. On the back of the programmer or display module, disconnect this cable connector from its socket (labelled Term) if present.

Note: Mark this connector and socket before removing if you are unsure of the wiring.

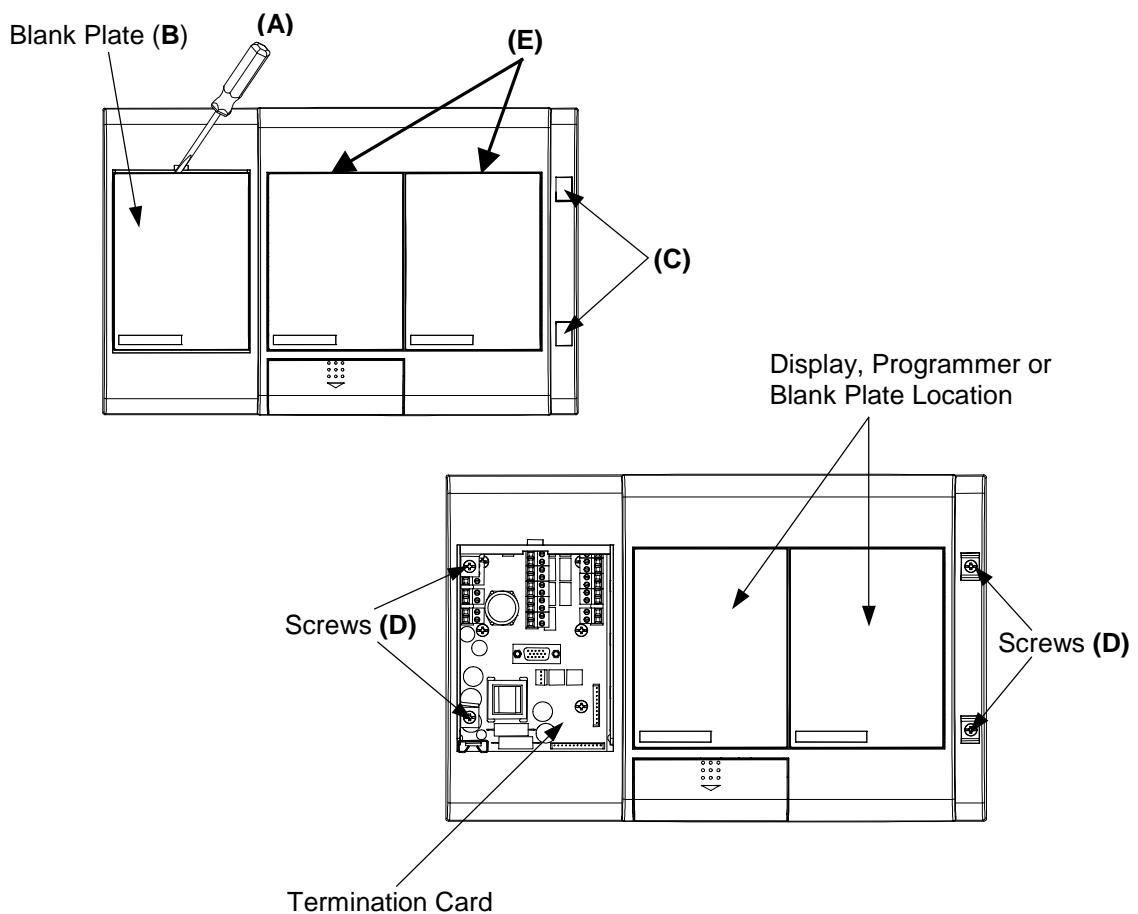

Figure 4 Removing the Blank Plate, Screw Covers, Retaining Screws, Programmer and Display Modules.

6.3 Component Location inside Detector Enclosure

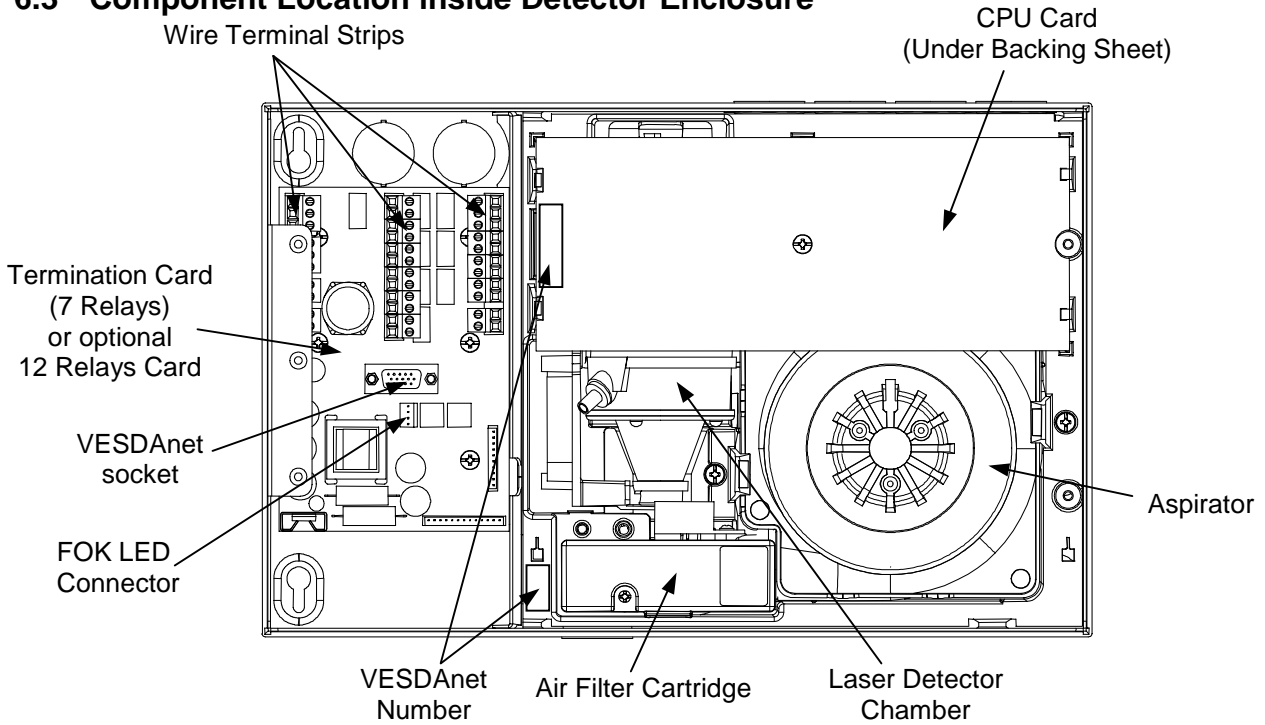

Figure 5 Components inside Detector Enclosure

6.4 Display and Programmer Module Orientation

The detector is shipped from the factory with the display, programmer and/or blank plates positioned in the normal orientation. Refer to Figure 3. If the detector is to be mounted in the inverted orientation, perform the following steps to rotate the modules.

- (a) Remove the front cover as per Section 6.2.
- (b) Locate the cable loom that connects the Central Processor Card to the display or programmer module located on the front cover. Remove this cable connector from its socket (labelled Term).
- (c) Insert a 4mm wide x 1mm flat blade screwdriver into gap between module and front cover (E). Refer to Figure 4.
- (d) Gently lever screwdriver to lift out modules.
- (e) Rotate modules 180° and gently re-insert into the same compartment until modules are flush with the front cover. Refer to Figure 3 for orientation. Ensure the metal fingers are located on the exterior of the Display/Programmer.
- (f) Re-connect the cable loom to the socket (labelled Term) on the display or programmer module. Refer to Figure 6 below for cable termination diagram.

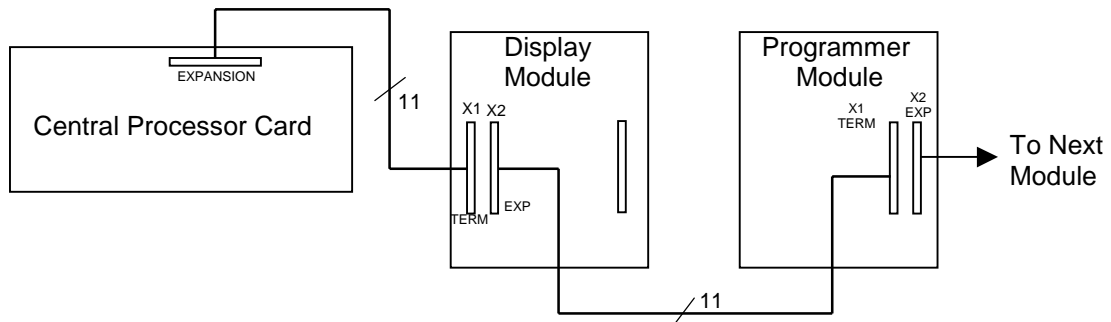

Figure 6 Cable Terminations between Modules and Central Processor Card

6.5 Removal of Metal Knockout Holes for Cable Entry

- (a) Determine the cable entry holes to be used. Refer to Figure 7.
- (b) Using the ball end of a small hammer, gently tap onto the required knockout holes to break away the metal pieces.

OR

Punch out the knockout holes with the blade of a screwdriver or a punch tool.

6.6 Exhaust Port Options

There are three exhaust air outlet positions (Bottom, Rear and Left Side) located on the exhaust air manifold. Refer to Figure 7. Any of these outlets may be used to vent the air into the atmosphere or back to the fire zone. Select an appropriate exhaust outlet to suit the site condition and remove the appropriate plug with a screwdriver.

If the side exhaust is to be used perform the following:-

- (a) Punch out the knockout hole located on the left side of the enclosure with the ball end of a small hammer or a screwdriver (A).
- (b) To remove the plug (B), insert a screwdriver into the slot on the plug and turn.
- (c) Run a 25mm (1in) pipe through the side hole and insert the pipe into the exhaust port ensuring there is a firm fit.
- (d) **Do not glue this pipe to the exhaust port.**

Caution: Do not remove the plug located at outlet (B) if there is no pipe attached to this outlet.

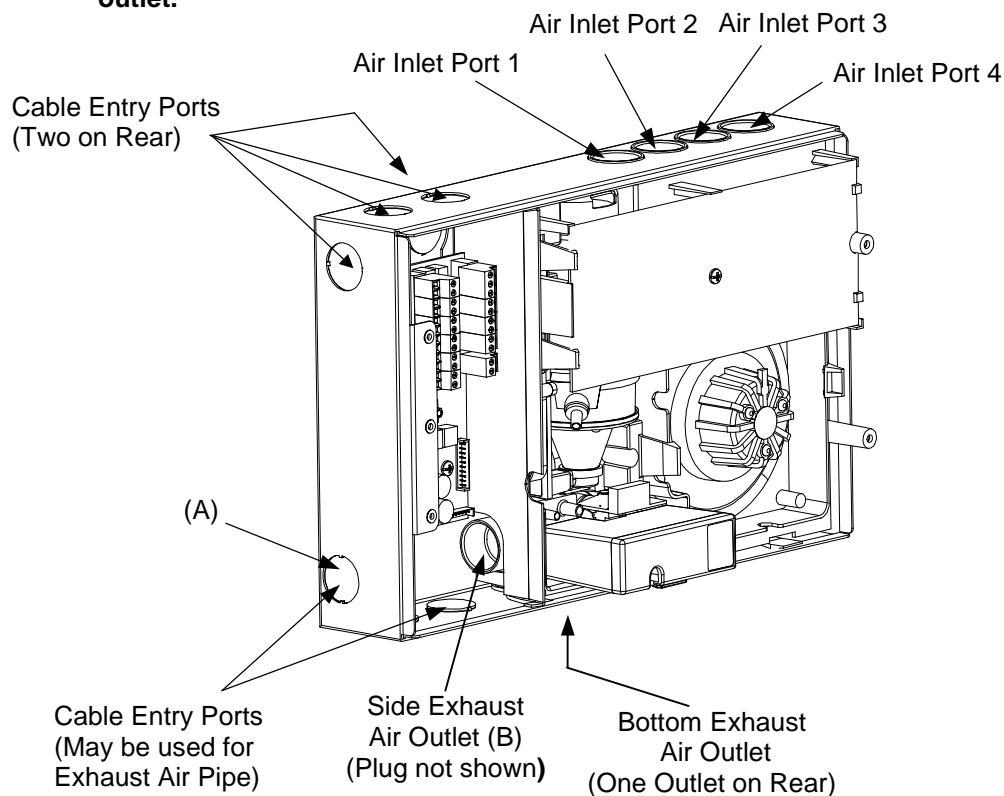

Figure 7 Exhaust Port Options and location of Cable Entry Ports

6.7 Securing the Mounting Bracket

Warning: Make sure that there are no electrical wires or plumbing behind the mounting position before drilling. Ensure the mounting position is flat.

- Remove the drilling template from the centre page of this manual.
- Determine the orientation for the detector (Normal or Inverted Orientation). Place the drilling template onto its mounting location in the correct orientation and drill out the appropriate holes. Refer to the drilling template for orientation.
- Use the appropriate fasteners to suit the mounting surface. Secure the bracket to the surface.

6.8 Attaching the Detector onto the Bracket

- Determine the required orientation for the LaserSCANNER. Refer to Figure 3 for orientation.
- Place the three bridges located on the rear of the detector onto the three lances located on the mounting bracket. Refer to Figure 8.
- Push the detector downwards until it locks onto the lances and engages the fitting dimples.
- Check the unit does not slip off its bracket.
- To remove, push the detector upwards and pull away from wall.
- To prevent unwanted removal of the detector, insert screw into the keyhole slot at location shown on template and tighten screw. Drill out these holes before mounting the detector onto its mounting bracket by using the supplied template to locate the screw hole position. Insert at least one screw into one key hole slot located around the Termination Card area.

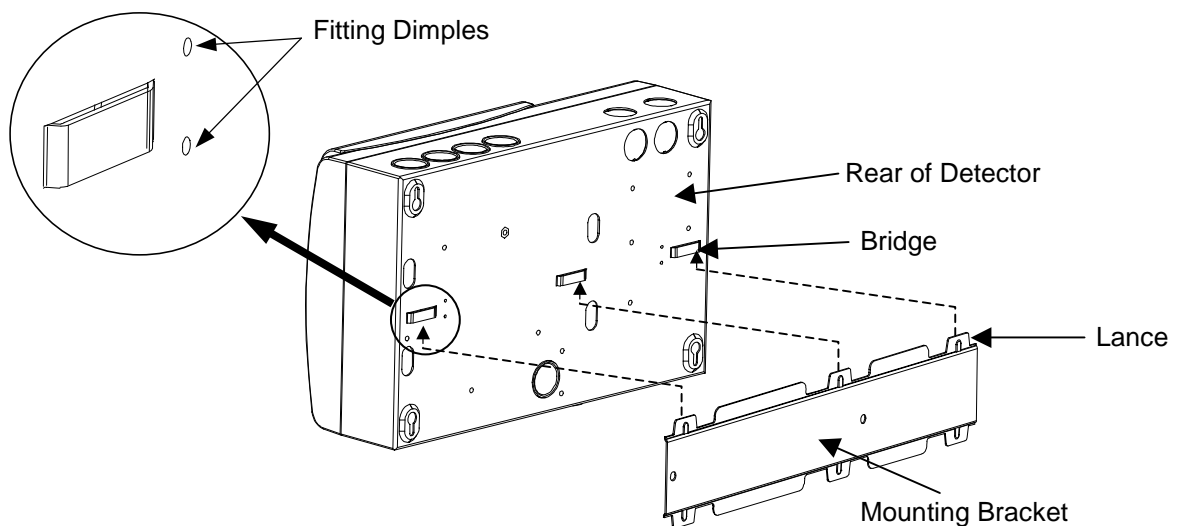

Figure 8 Mounting the Detector onto the Mounting Bracket

6.9 Connecting the Air Sampling Pipe

The air inlet ports are designed to fit a standard pipe of 25mm (1in) OD. A tapering of the air inlet ports prevent the pipes from being inserted beyond 15mm (5/8in).

Any of the four inlet ports may be used. Ensure that the correct pipes in use are selected when programming the detector.

Note: *There must be a length of 500mm (19.6in) of straight pipes before terminating the pipes at the air inlet ports of the detector.*

Note: *When using a 3/4 inch pipe which has a 1 1/16 inch OD, use the adaptor supplied with the LaserSCANNER to connect the pipes to the inlet manifold.*

- a) De-burr and square off the end of the sampling air pipes. Ensure the pipes are free from swarf.
- b) Remove the plugs from the inlet and exhaust ports. **Do not remove the plugs from the inlet ports if the ports are not used.**
- c) Insert the pipes into the inlet and/or exhaust ports ensuring a firm fit. **DO NOT** glue these pipe connections.
- d) Pipe the exhaust air where necessary.

Caution: DO NOT GLUE THE AIR INLET AND EXHAUST PIPE CONNECTIONS. Glued connections make disconnecting the sampling air pipes from the LaserSCANNER extremely difficult during maintenance and will result in damage to the equipment.

6.10 Cabling Using Glands and Conduits

6.10.1 Using Glands

- (a) If using cable glands, use the correct gland size to fit into the 25mm (1in)Ø cable entry port.
- (b) Run the wires through the glands and into the LaserSCANNER enclosure. Use your local codes and electrical standards for cabling.

6.10.2 Using Conduits

- (a) Terminate the conduits at the cable entry ports on the sides of the box using the appropriate conduit connectors.
- (b) Run the wires through the conduits and into the LaserSCANNER enclosure. Use your local codes and electrical standards for cabling.

6.11 Termination Card Details

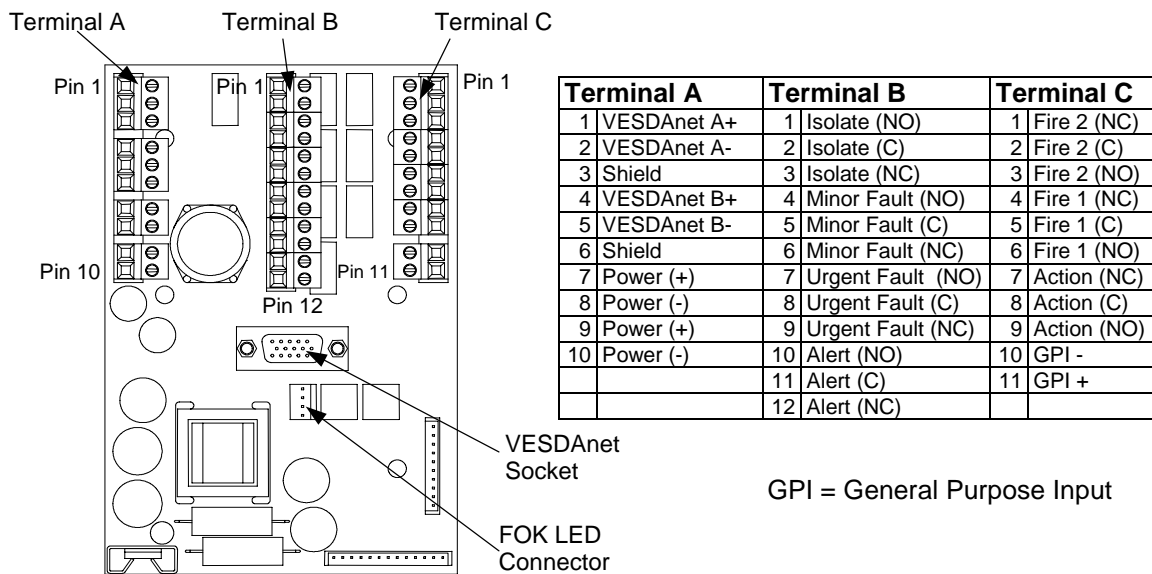

Figure 9 Termination Card Details for 7 Relays

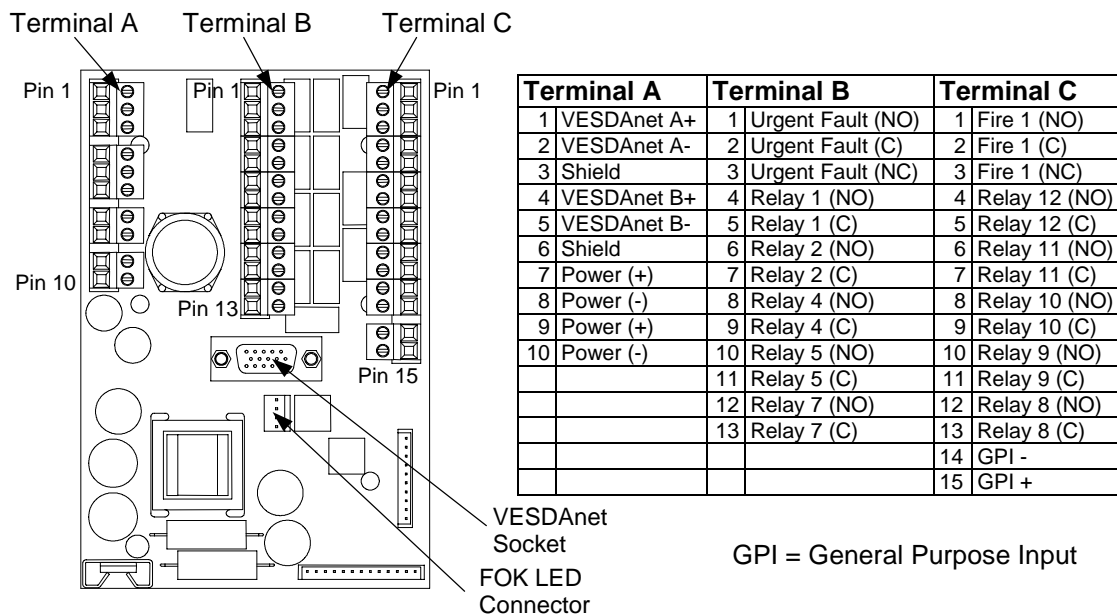

Figure 10 Termination Card Details for 12 Relays

6.12 Procedure to Terminate Wires to the Termination Card

Use the appropriate local wiring standards or use the following suggested procedure listed below. Check Sections 6.13, 6.14 and 6.15 for specific information on terminal connections.

- (a) Strip off 5 to 7mm (0.2 to 0.3in) of outer insulation from each wire.
- (b) For multi-stranded wire only - Twist wire strands together.

- (c) On the termination card, remove the plugs from its terminal sockets.
- (d) Insert the correct wires into the terminal plugs.
- (e) Tighten terminal plug screw.
- (f) Repeat steps (c) to (e) as required.
- (g) Insert plugs into the correct sockets on the termination card.
- (h) Check the wires are attached to its terminals.
- (i) Ensure no bare wires are exposed at the terminals. The wire insulation must touch the terminal plugs at the pin connection opening.
- (j) Check the terminations are correct by referring to the appropriate circuit diagrams in Sections 6.13, 6.14 and 6.15.

6.13 Terminating the Power Wires to the Termination Card

- a) Refer to Figure 9 or 10 for the location of the power terminals on the termination card.
- b) Connect the power wires to the Power terminals as shown in Figure 11.

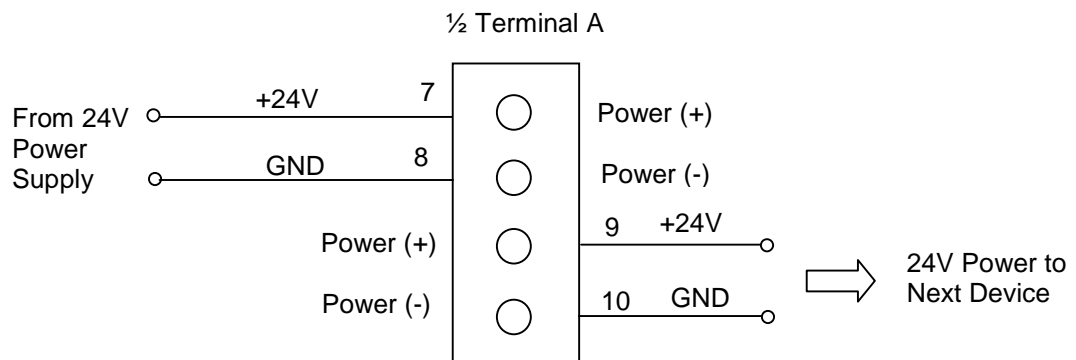

Figure 11 Wire Connection Details for Power

6.14 Connecting the VESDAnet Wires to the Termination Card (If required)

- a) Refer to Figure 9 or 10 for the VESDAnet terminal location on the termination card.
- b) Connect the VESDAnet wires as shown in Figure 12. This diagram is only an example for five detectors. This wiring method is similar for two or more detectors.
- c) Maintain the wiring polarity throughout the network. **Do not leave any VESDAnet terminals unconnected.**

NOTE: The detector is shipped from the factory with the VESDAnet terminals linked as shown in Figure 13. If the detector is not to be used in a VESDAnet loop and is to be used as a stand-alone detector the VESDAnet terminals must be wired as per Figure 13.

NOTE: It is strongly recommended that the Closed Loop configuration shown in Figure 12 is installed, to achieve a redundant fault tolerant loop. An Open Loop configuration is possible by not linking the VESDAnet wires between detector 1 and detector 5. Detector 1 and detector 5 must be programmed to the Opened Loop Configuration.

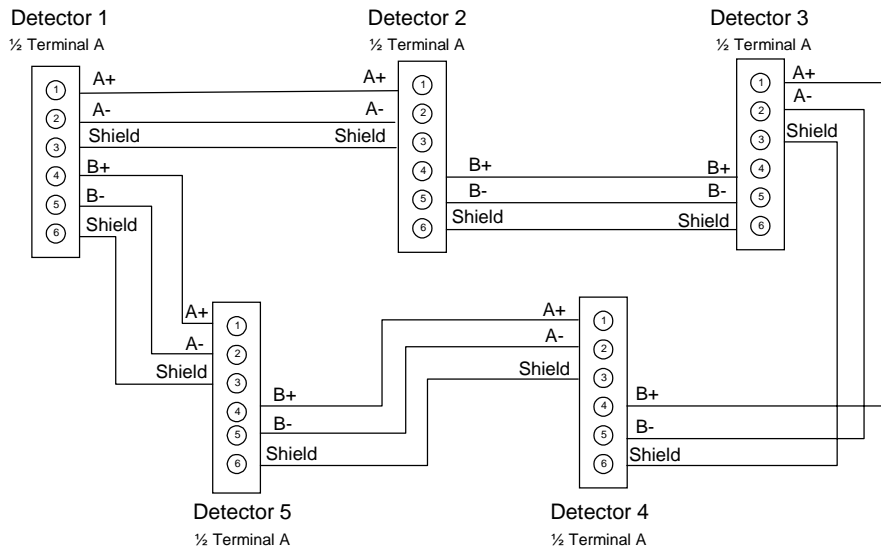

Figure 12 Wire Connection Details for VESDAnet (Closed Loop)

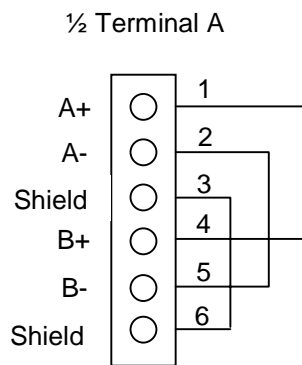
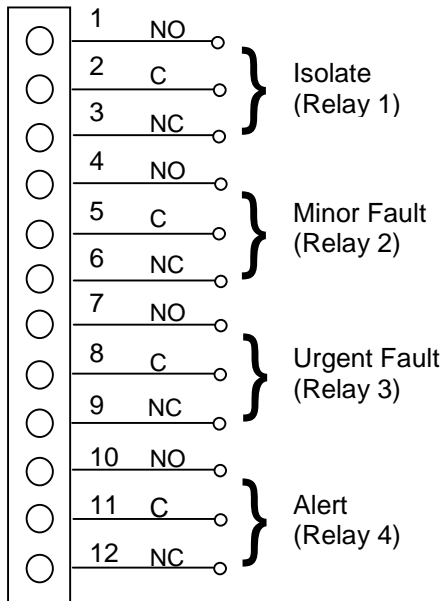

Figure 13 Wire Connection Details for VESDAnet Loop (Stand Alone Set Up)

6.15 Terminating the Relay Wires to the Termination Card

- a) Refer to Figure 9 or 10 for the relay terminals location on the termination card.
- b) Connect the relay wires to the terminals as per Figure 14 and your site requirements.

Terminal B



Terminal C

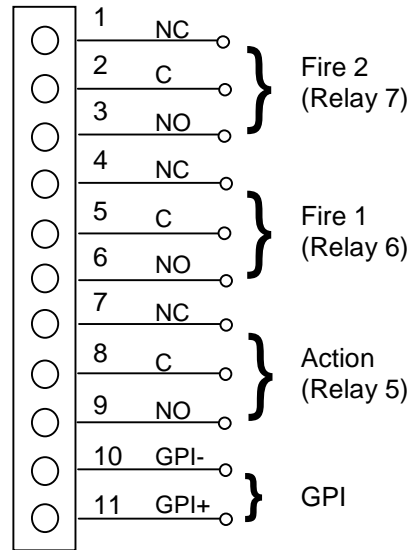

Terminal Pins location for 7 Relays (Default Relay Assignments)

Terminal B

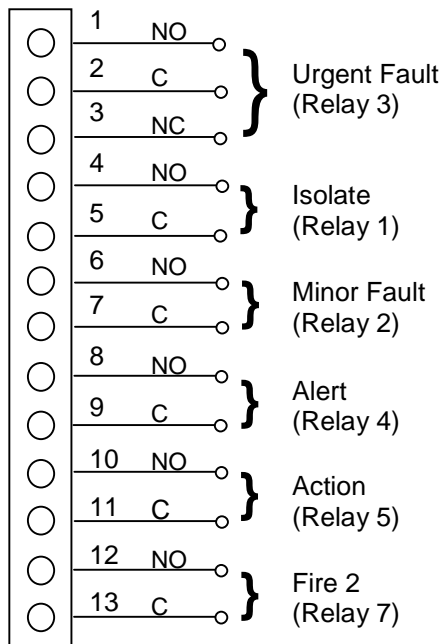

Terminal C

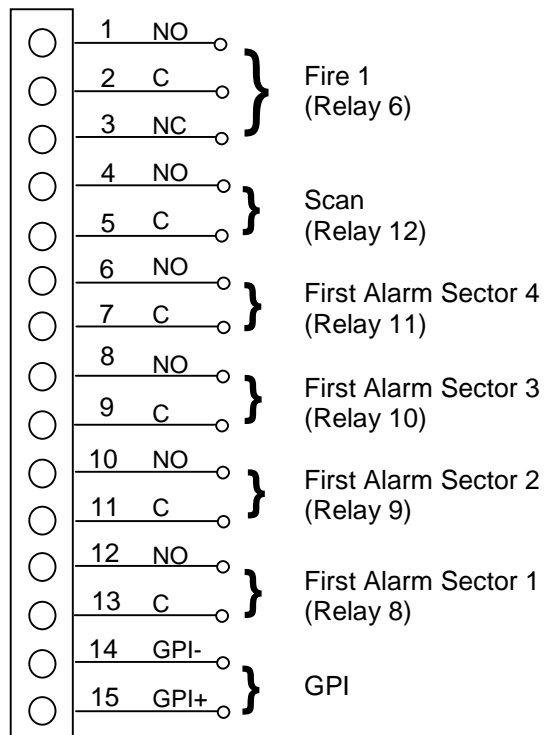

Terminal Pins location for 12 Relays (Default Relay Assignments)

Figure 14 Wire Termination Details for 7 and 12 Relays

6.16 Closing Up the LaserSCANNER

- a) Tie all wires together into neat looms using cable ties.
- b) If the front cover was removed do the following:-
 - i) Reattach the plastic straps to the front cover.
 - ii) Re-connect the removed cable loom to the **Term** socket located on the rear of the display or programmer module.
- c) Perform the power up as per section 7 and preliminary checks as per section 8.
- d) Close up the LaserSCANNER and secure the cover with the four screws.
- e) Re-attach the blank plate and screw covers to its location.

6.17 Pipe Bonding Check

- (a) Check all the pipe joints are fully sealed and bonded to eliminate unwanted air leaks.
- (b) Check the pipe joints at the air inlet ports of the LaserSCANNER **ARE NOT** bonded and the pipe fits firmly into the air inlet socket.
- (c) Check all pipes are securely attached to a mounting surface with the proper fasteners.
- (d) Check the number and sizes of the sampling air holes on the pipes are correct.
- (e) Check the routing of the pipes is correct with reference to the site plan.

7. Power Up

Caution Powering up the system must be done by VESDA accredited personnel.

7.1 Power Up the System

- (a) **Disconnect the power terminals** from the Termination card before turning ON the power.
- (b) Turn ON the power to the detector.
- (c) Check the voltage at the **Power** terminals is **24VDC+/-6V**. If the voltage is out of specification, turn OFF the power and troubleshoot.
- (d) If the measured voltages are within specification, then reconnect the terminal plugs and turn on the power.
- (e) Repeat measurements for other detectors connected onto the same power supply routing.
- (f) The system takes approximately 15 seconds to power up.
- (g) If the system fails to power up:-
 - Check all power wires are secured to its terminals.
 - Check the polarities of the power wires are correctly terminated.
- h) On power up.

The aspirator starts up and air is felt flowing out of the exhaust port.

If a Programmer module is fitted, the VESDA name will appear on the LCD screen.

If a Display module is fitted, the following indicators are lit:-

- Fire Alarm Threshold indicators
- Smoke Threshold Levels on Bar Graph
- 2 digit indicator
- Various fault indicators if there are any faults
- System OK indicator if there are no faults

If any of the above does not happen, contact your commissioning engineer or distributor to troubleshoot.

Note: The detector may show faults immediately after power up and this is normal. Reset the detector by pressing the RESET switch on the front cover of the detector to unlatch the relays and fault lights. The fault lights on the front cover will light up and this is normal. Proceed to section 8.

8. Preliminary System Checks

Perform the following preliminary system Setup and checks before commissioning.

- (a) Logging onto the system with a PC or a LCD Programmer. See Section 8.1.
- (b) VESDAnet communication checks. See section 8.2
- (c) Normalise the airflow. See section 8.3
- (d) Basic pass/fail smoke test. See section 8.4

8.1 Logging On to the System

Check with your distributor for the default User Levels and PIN numbers to log on to the system. **Fault code 25 or 26** is generated when a LCD Programmer or a PC-Link HLI device is connected to the VESDAnet socket. This fault clears when the programming device is disconnected from the detector.

Procedure	LCD Programmer Module	Hand Held LCD Programmer	PC Programmer
Connecting the programming device to a Detector or to a VESDAnet socket.	No physical connection required	Plug the LCD Programmer cable into the VESDAnet socket on the Termination card or to a remote terminal. Refer to Figure 5 for location of the VESDAnet socket on the Termination Card.	Connect the PC via a PC-Link HLI device to the VESDAnet socket on the Termination Card or to a remote terminal. Refer to Figure 5 for location of the VESDAnet socket on the Termination Card.
Logging onto the system.	Press any programmer key to display the Logon screen.	Press any programmer key to display the Logon screen.	Run VConfig Basic or VConfig Pro program from the PC.
Enter your Access Level and PIN Number.	Use the Programmer keys to enter your access level and PIN number. Press ↵ when completed.	Use the Programmer keys to enter your access level and PIN number. Press ↵ when completed.	Enter your Access Level and PIN Number when the Logon screen appears.

8.2 VESDAnet Communication Check

Note: This test verifies the VESDAnet system is functioning correctly and all devices connected on VESDAnet are communicating. Write down the VESDAnet number for each detector, programmer and display module. The location of the VESDAnet number for the detector is shown in Figure 5. The programmer and display modules have this number located at the bottom left hand side of the front face.

If any of the listed VESDAnet numbers and devices are incorrect, check the VESDAnet wiring to all devices.

Procedure	LCD Programmer	PC Programmer
Display the VESDAnet numbers.	<ul style="list-style-type: none"> • Select Show Wiring Order ↵. • Read the displayed devices and VESDAnet numbers. • Check the details with your list. 	<ul style="list-style-type: none"> • Select the Device Tree command from the View menu. • From the Device Tree window, click on all the + signs to expand the tree. • Check all the listed devices and VESDAnet numbers against your list.

8.3 Normalise the Air Flow and Clearing Air Flow Faults

Note: This procedure normalises the airflow for all pipes in use and takes approximately 11 minutes. It is important to correctly select the pipes in use before Normalising. Check the airflow is approximately 100% when completed.

Procedure	LCD Programmer	PC Programmer
Set the Air Pipes in use for sampling.	<ul style="list-style-type: none"> • Select Setup by Zone ↵ Zone Number ↵ Detector ↵ Air Flow ↵ Flow Control ↵ • Set the pipes in use for sampling. ✓ = Selected. 	<ul style="list-style-type: none"> • Select Device Tree from View menu • From the Device tree window, click on all the + sign to expand the tree. • Double click on detector to open a window with multiple tabs. • Click on the Airflow tab when window appears. • Select the pipes in use. ✓ = Selected. • Click on the Apply button.
Set the Aspirator Speed.	<ul style="list-style-type: none"> • Select Setup by Zone ↵ Zone Number ↵ Detector ↵ Air Flow ↵ Flow Control ↵ • Set the Aspirator RPM value by using the arrow keys. Set the value as per the ASPIRE calculation for that site. 	<ul style="list-style-type: none"> • In the same window that displays the Airflow tab, click on the Aspirator tab. • Change the Aspirator RPM to the value as per the ASPIRE calculations. • Click on the Apply button.
Normalise the Airflow. Wait for 11 minutes to complete Normalising.	<ul style="list-style-type: none"> • Select Setup by Zone ↵ Zone Number ↵ Detector ↵ Air Flow ↵ Normalise ↵ Normalise Start ↵ 	<ul style="list-style-type: none"> • Select the Normalise Airflow command from the Device menu. • Check the Active Events List displays the alarm. • Check in the Device tree window, the word Normalising appears next to the Detector being Normalised.
Check the Airflow after Normalising is approximately 100%.	<ul style="list-style-type: none"> • Select Setup by Zone ↵ Zone Number ↵ Detector ↵ Air Flow ↵ Normalise ↵ <i>Current % Flow</i> OR • Select Setup by Zone ↵ Zone Number ↵ Detector ↵ Status ↵ 	<ul style="list-style-type: none"> • Double click on the Detector being Normalised. • Click on the Current Flow tab in the window with multiple tabs.
Reset the Detector.	<ul style="list-style-type: none"> • Select Setup by Zone ↵ Zone Number ↵ Detector ↵ Zone Control ↵ Reset Start ↵ 	<ul style="list-style-type: none"> • Click on the Reset icon or select Reset from the Zone menu.

Note: Detectors with software version 3.x.x and above will have a Normalising fault (77) reported during the Normalising process.

8.4 Basic Pass/Fail Smoke Test

Note: This test verifies the detector will sense smoke. It does not replace any appropriate commissioning test. Use the table below to perform this test by using one of the following devices.

Procedure	Display Module	LCD Programmer	PC Programmer
Isolate the Detector.	<ul style="list-style-type: none"> Press the Isolate button located on the Display. Check the Isolated indicator lights up. 	<ul style="list-style-type: none"> Select Setup by Zone ↓ Zone Number ↓ Detector ↓ Zone Control ↓ Isolate <i>Start</i> ↓ Select Setup by Zone ↓ Zone Number ↓ Detector ↓ Status ↓ and check the detector is Isolated. 	<ul style="list-style-type: none"> Select Device Tree from the View menu. Select the detector to be Isolated from the Device Tree window. Click on the Isolate icon or Isolate Zone command from the Zone menu. View Active Events list for response to Isolation.
Inject Smoke into any one of the sampling air pipes and observe the following events.	<ul style="list-style-type: none"> Scan starts Sounding device on Detector beeps. Red LEDs on front panel lights up. Smoke bar graph indicator lights up showing smoke level. 2 digit indicator shows smoke intensity level when Smoke Level is selected. 	<ul style="list-style-type: none"> Select Setup by Zone ↓ Zone Number ↓ Detector ↓ Status ↓ and check the smoke level value. Alarms reported in Status menu. 	<ul style="list-style-type: none"> Sounding device on the Detector beeps. Smoke alarm displays on the Active Events List window.
After the smoke has cleared, Reset the Detector to clear the alarms.	<ul style="list-style-type: none"> Press the Reset button once to clear the alarms and various fault indicators. 	<ul style="list-style-type: none"> Select Setup by Zone ↓ Zone Number ↓ Detector ↓ Zone Control ↓ Reset <i>Reset</i> ↓ 	<ul style="list-style-type: none"> Click on the Reset icon or select the Reset command from the Zone menu.
De-Isolate the detector.	<ul style="list-style-type: none"> Press the Isolate button once. The Isolated indicator goes off. 	<ul style="list-style-type: none"> Select Setup by Zone ↓ Zone Number ↓ Detector ↓ Zone Control ↓ Isolate <i>Stop</i> ↓ Select Setup by Zone ↓ Zone Number ↓ Detector ↓ Status ↓ and check the Isolated alarm is cleared. 	<ul style="list-style-type: none"> Select the Device Tree command from the View menu. Click on the detector to be De-Isolated from the Device Tree window. Click on the De-Isolate icon or select the De-Isolate Zone command from the Zone menu. View Active Events list for the Isolated alarm to clear from the list.

9. Installation Checklist

Site Name:

Zone:

Detector Serial Number/s:

Perform the following checks listed below to ensure that all the necessary items are completed before handing over to a commissioning engineer.

INSTALLATION CHECKS	Yes	No
1. Was the LaserSCANNER detector intact in the box?	<input type="checkbox"/>	<input type="checkbox"/>
2. Is the LaserSCANNER securely locked onto its mounting bracket?	<input type="checkbox"/>	<input type="checkbox"/>
3. Are the sampling air pipes firmly connected to the air inlet ports? Note- The pipes must not be glued.	<input type="checkbox"/>	<input type="checkbox"/>
4. Have the power wires been connected to the correct terminals on the termination card?	<input type="checkbox"/>	<input type="checkbox"/>
5. Have the alarm signalling wires been terminated to the correct terminals on the termination card?	<input type="checkbox"/>	<input type="checkbox"/>
6. Have the VESDAnet wires been connected to the correct terminals on the termination card?	<input type="checkbox"/>	<input type="checkbox"/>
7. Has the plug at the exhaust port been removed and the exhaust pipe (if fitted) not glued?	<input type="checkbox"/>	<input type="checkbox"/>
8. Has the front cover been replaced correctly?	<input type="checkbox"/>	<input type="checkbox"/>
9. Have the Preliminary System Checks been performed?	<input type="checkbox"/>	<input type="checkbox"/>
10. Is the air sampling pipework installed and checked as per the site plans?	<input type="checkbox"/>	<input type="checkbox"/>

Installation of your LaserSCANNER is now complete.

Name of Installer:

Signature:

Date:

10. VESDA Product Warranty Conditions

1. Vision Systems warrants that new VESDA products (excluding consumable items) will conform to its published specifications and remain in good working order during the warranty period of 24 (twenty four) months from date of shipment from Vision Systems.
2. Vision Systems also warrants that product serviced or repaired by its service department will remain in good working order for a warranty period of 12 (twelve) months from the date of service. This service or repair warranty is only available on product less than 7 (seven) years old and only covers those component parts of the product serviced, repaired or replaced.
3. Should product under warranty not be in good working order, Vision Systems will, at its option, either repair or replace the product or its component parts at no additional charge.
4. Spare parts and replacement product, covered under this warranty, will be furnished on an exchange basis and will, at the option of Vision Systems either be new, equivalent to new or reconditioned. Returned parts and products to Vision Systems becomes the property of Vision Systems.
5. This warranty does not cover the repair or damage to the product resulting from negligence or misuse, improper storage or handling of the product; from accident or disaster; from use of non- Manufacturer modifications to the product other than in accordance with Vision Systems instructions; attachment of features not approved by Vision Systems in writing; or services by persons not authorised by Vision Systems in writing to service the product.

Warranty service may be obtained by:

1. Notifying Vision Systems and giving full description of fault.
2. Vision Systems will first attempt to rectify fault by supplying replacement component parts.
3. If rectification is not achieved by component part replacement then distributor is to return faulty product to Vision Systems at Vision Systems cost once Vision Systems has given approval to do so.



Australia and Asia

Vision Fire & Security
Private Bag 215
495 Blackburn Road
Mount Waverley, VIC, 3149
Australia
Ph +61 3 9211 7200
Fax +61 3 9211 7201
Free Call 1 800 700 203

The Americas

Vision Fire & Security
700 Longwater Drive
Norwell, MA 02061, USA
Ph +781 740 2223
Toll Free 800 229 4434
Fax +781 740 4433

Europe and the Middle East

Vision Fire & Security
Vision House, Focus 31 Mark Road
Hemel Hempstead
Herts, HP2 7BW UK
Ph +44 1442 242 330
Fax +441442 249 327

www.vesda.com