



LCD Programmer Quick Reference Guide

LaserPLUS™ (VLP)

LaserSCANNER™ (VLS)

LaserCOMPACT™ (VLC 505)

Scope of this Manual

This manual is to be used as a quick reference guide to perform the initial detector setup and is not to be used for commissioning. However, the menu trees may be used at any time as a reference document to locate a particular command, function or parameter located somewhere within the menu tree.

What is the LCD Programmer?

The LCD Programmer is a LCD display and keyboard device that enables the user to interface with the VESDA equipment through VESDAnet. The user is able to perform the following functions:-

- Programs a device or devices
- View the system status and event log
- Perform system diagnostics
- Change from defaults values
- Set new PIN numbers

About the Programmer Keys

The two rows of keys on the programmer are used to move the cursor and to select the various options on the LCD screen. See the table below for the function of each key. The menu trees overleaf help you navigate to the required command.

Key	Function
◀ ▶	Moves the cursor to the right or left on the screen. Scrolls highlighted item left/right.
▲ ▼	Moves the cursor up or down the screen. Scrolls the menu up or down.
+	Increases the value of the displayed number. Adds a selected letter from the displayed alphabet list. Page Up on some screens.
-	Decreases the value of the displayed number. Deletes a selected letter. Page Down on some screens.
ESC	Moves back up the menu tree. Any changes to parameters are actioned after acknowledging the check message "Do you want to save the changes"?
↵	Moves down the menu tree by selecting the highlighted option. Adds selected letter. Toggles between values.

Soft Keys

These are the ▲ ▼ ◀ ▶ keys on the top row. Use the keys located directly below these commands (**NO**, **BACK**, **YES**, **CONT**, **EXIT**, **QUIT** or **WAIT**) when displayed, to respond.

Software Versions for Menu Trees

PRODUCT	SOFTWARE VERSION
LaserPLUS	3.05.00 & previous
LaserSCANNER	3.05.00 & previous
LaserCOMPACT (VN)	3.07.05
LCD Programmer	3.02.01
Display	3.00.01 & previous

Hour Glass Symbol

This symbol is displayed when the LCD Programmer is waiting for the updated data from the system after executing a command. Press one of the keys located below the CONT or WAIT command to proceed without waiting. It will disappear automatically when the data arrives.

User Levels and PIN Numbers

There are three user levels and a four-digit Personal Identification Number (PIN) number for each level to be entered at LOGON. The three preset user levels are **USR**, **ADM** and **DST**. All VESDA products are shipped with a factory set default PIN number for each user levels. These user levels and PIN numbers can be changed when the VESDA system is programmed.

USER LEVEL	FUNCTIONAL DESCRIPTION
USR	This is the USER level. A USER can view the event log, change the date and time and perform some zone control functions only.
ADM	This is the ADMINISTRATOR level. An ADMINISTRATOR has access to most of the functions and parameters including setting alarm thresholds, normalising the airflow and defining the relay configuration.
DST	This is the Distributor level and is the highest level. A DISTRIBUTOR has unlimited access to all the system commands and parameters.

Connecting the LCD Programmer to the Device

1. Plug one end of the data cable into the 15-pin socket on the programmer.
2. Plug the other end of the data cable into the programming socket on the termination card in the detector or to a remote VESDAnet terminal socket.
3. Wait 30 seconds for the programmer to power up and press any key to see the LOGON screen.

Note: Plugging the programmer into the network will cause a Network fault to be generated. To clear the network fault, select System All Devices ↵ System Control ↵ and Reset. See Menu tree 4.

Logging On to the System

1. If the programmer is already connected, press any key to see the LOGON screen otherwise refer to "Connecting the LCD Programmer to the Device."
2. Enter your User ID by using the +/- keys to scroll through the user levels.
3. Press the ▶ key to move the cursor to the PIN field.
4. Use the +/- keys to increase or decrease the displayed number.
5. Press the ▶ key to move to the next number.
(The ◀ key moves the cursor back to the previous number.)
6. Repeat steps 4 and 5 until all four numbers are entered.
7. Press ↵ key when the four digit number have been entered.

Note: A user may bypass the LOGON procedure to enter into the system. The user may only read the data and cannot change any values.

Logging Off the System

1. Press the ESC key until the Warning screen is displayed.
2. Confirm the LOGOFF with the YES or NO key.
3. The LCD now displays the LOGON screen.
4. Press the ESC key to display the VESDA logo.

The programmer automatically LOGS OFF after 10 minutes when not used. Two series of warning beep sounds and two warning messages display at 60 seconds and 15 seconds before LOGOFF. To resume operation before the system LOGOFF press any key to cancel the operation.

The PIN Challenge System

The PIN challenge system gives the user three attempts to enter the correct PIN number. Failing to enter the correct PIN number on the third attempt the Programmer stops all further entries for 10 minutes. A four-digit number and the Vision System-VESDA office telephone number will be displayed on the LCD screen. Call this number for assistance. No further entries can be made until instructions have been received from the VESDA office.

Note: PIN numbers are disclosed to authorised personnel attending accredited VESDA training courses.

Navigating around the Menu Trees

The menu tree is a map that guides the user to move between commands, to change or view parameters and to execute the system functions. To select the next command located at the next level in the menu tree, move the highlighted cursor to the required command by using the ▲ or ▼ keys. Press the ↵ key to activate the highlighted option or command.

To move back up the tree, press the **ESC** key until the required function is reached. Press the ▲ or ▼ keys to move up and down the menu and select the next command. When any parameter has been changed, a message "Do you want to save the changes?" is displayed. Respond to this question by selecting one of the displayed options NO, YES or BACK. Select one of the keys on the top row located directly below one of the options.

Programming the VESDA Detector to meet the minimum requirements for the system to operate

1. Determine the type of detector to be programmed. Refer to the main menu tree for detector type.
2. After Log On, select Setup by Zone ↵ select 0... (0=Unconfigured Zone) ↵ select one of the detectors displayed on the list (VLP Detector or VLS Detector or VLC Detector). This takes the user to one of the menu trees in 1a, 1b or 1c on the next page. The menu tree that appears on the display screen depends on which detector was selected.
3. Determine which function is to be performed by referring to the highlighted commands in the appropriate tree. Move the ▲ or ▼ keys to the required command located in the first column of the menu tree. Press the ↵ key to select the function. This moves the cursor position into the second column of the menu table.
4. Press the ▲ or ▼ keys to move through the menu as before and select the appropriate function with the ↵ key.
5. Use the **ESC** key to move back to the previous menu.

Examples for Setting Up the Detectors

To Set Time and Date

After Log On, select System/All Devices ↵ Set Date & Time ↵ and alter the date and time by using the ▲ ▼ ◀ ▶ + - keys to change the values. Press the ESC key to move back up the menu tree and respond to the displayed message about saving the changes.

To View the Status of the Detector

Select Setup By Zone ↵ 0... ↵ select VLP Detector or VLS Detector or VLC Detector (if detectors are displayed) ↵ Status ↵

To Normalise the Air Flow

Select Setup By Zone ↵ 0... ↵ select VLP Detector or VLS Detector or VLC Detector (if detectors are displayed) ↵ Air Flow ↵ Normalise ↵ Start ↵

To Start Auto Learn

Select Setup By Zone ↵ 0... ↵ select VLP Detector or VLS Detector or VLC Detector (if detectors are displayed) ↵ Auto Learn ↵ Auto Learn Start ↵

Main Menu

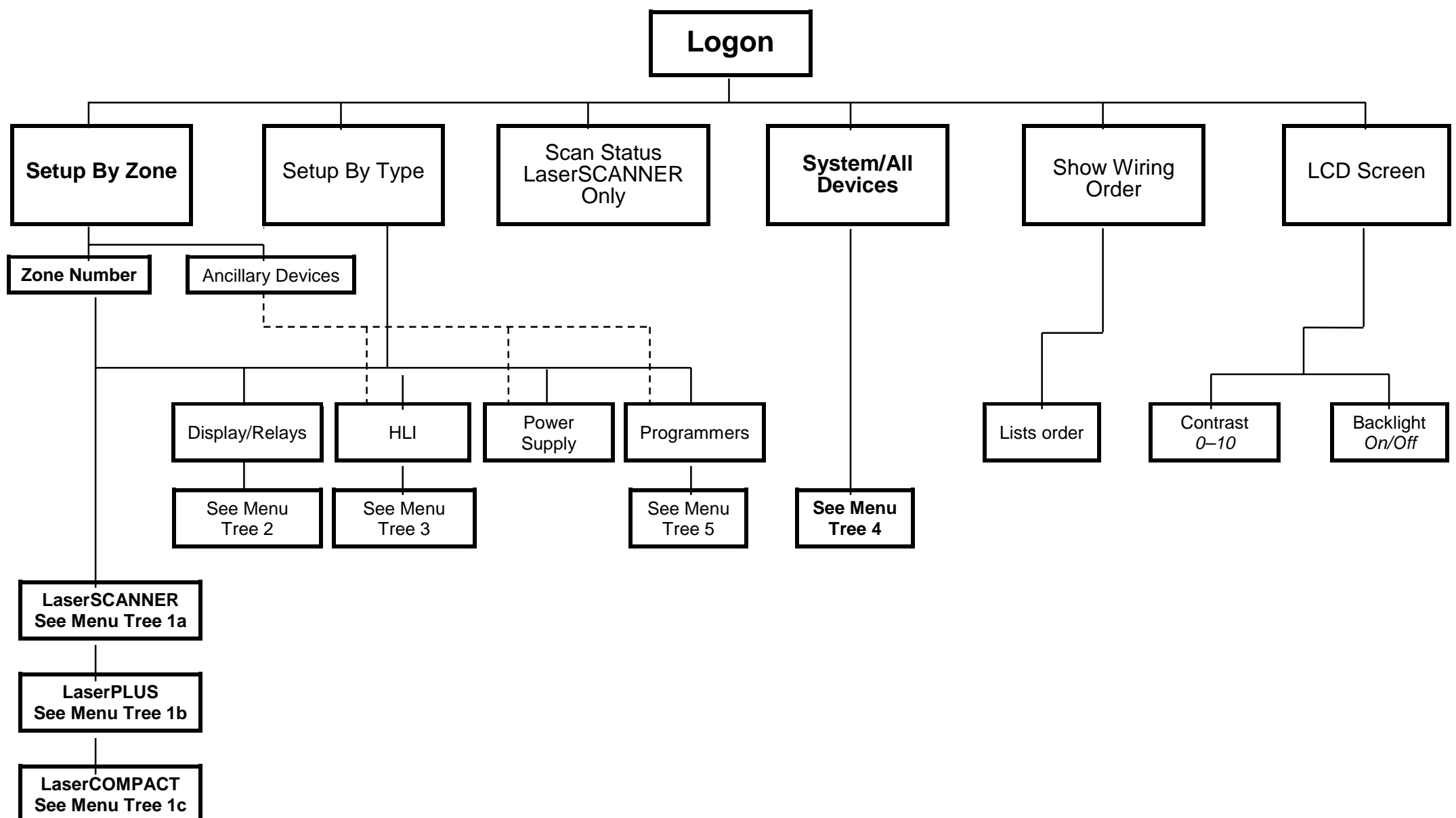

Menu Tree 1a – LaserSCANNER Detector

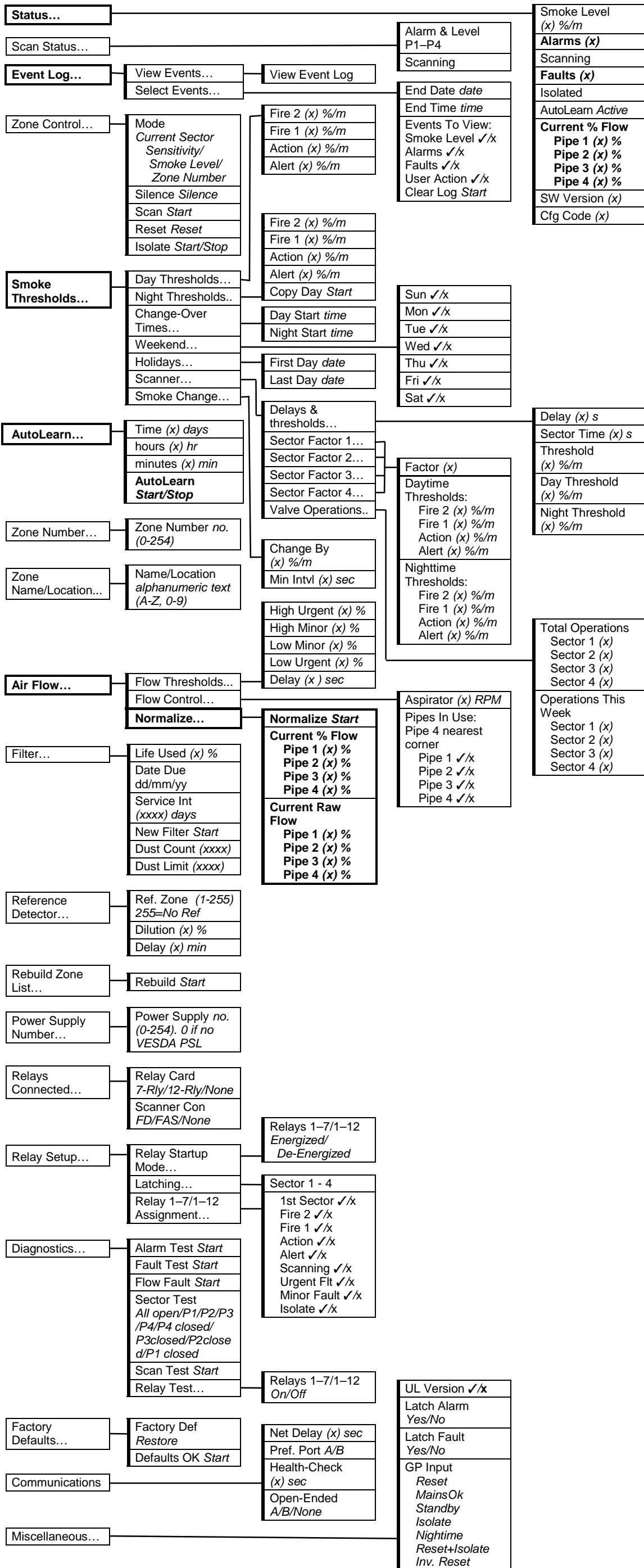

Menu Tree 1b – LaserPLUS Detector

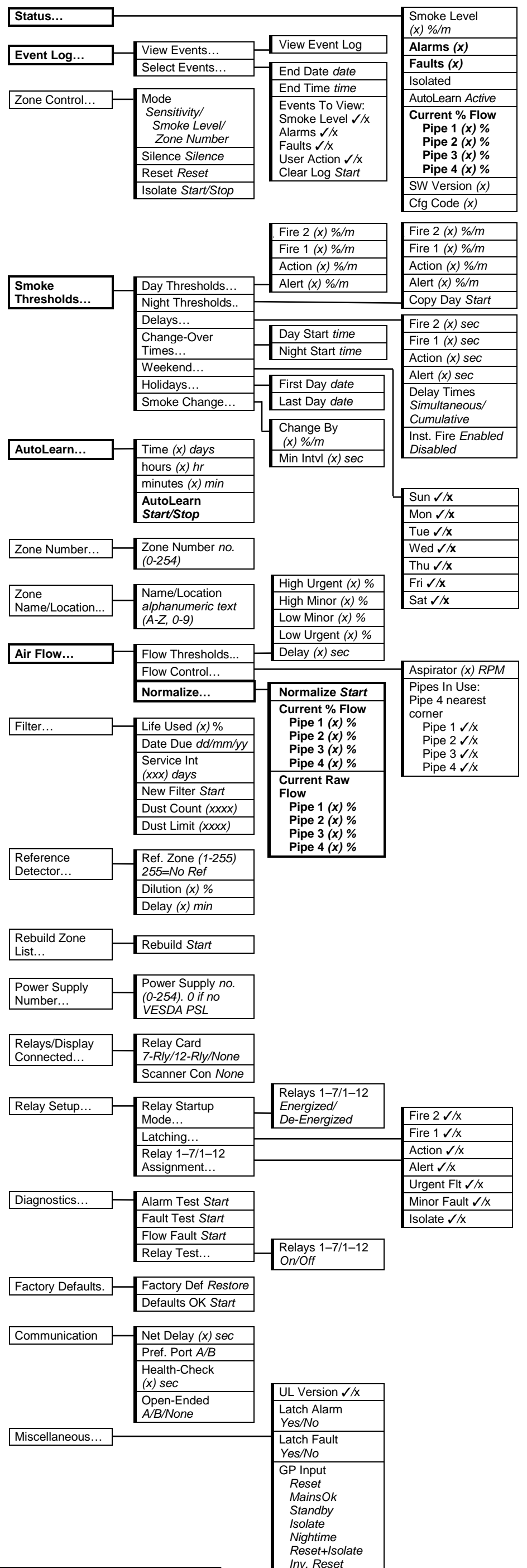

- (x) = Numerical value shown on display.
- Units of measure shown are in metric.
- Imperial units of measure are displayed when US unit is selected from the Miscellaneous menu. See Menu Tree
- Highlighted items are the minimum requirements to enable successful system operation.

Menu Tree 1c – LaserCOMPACT Detector

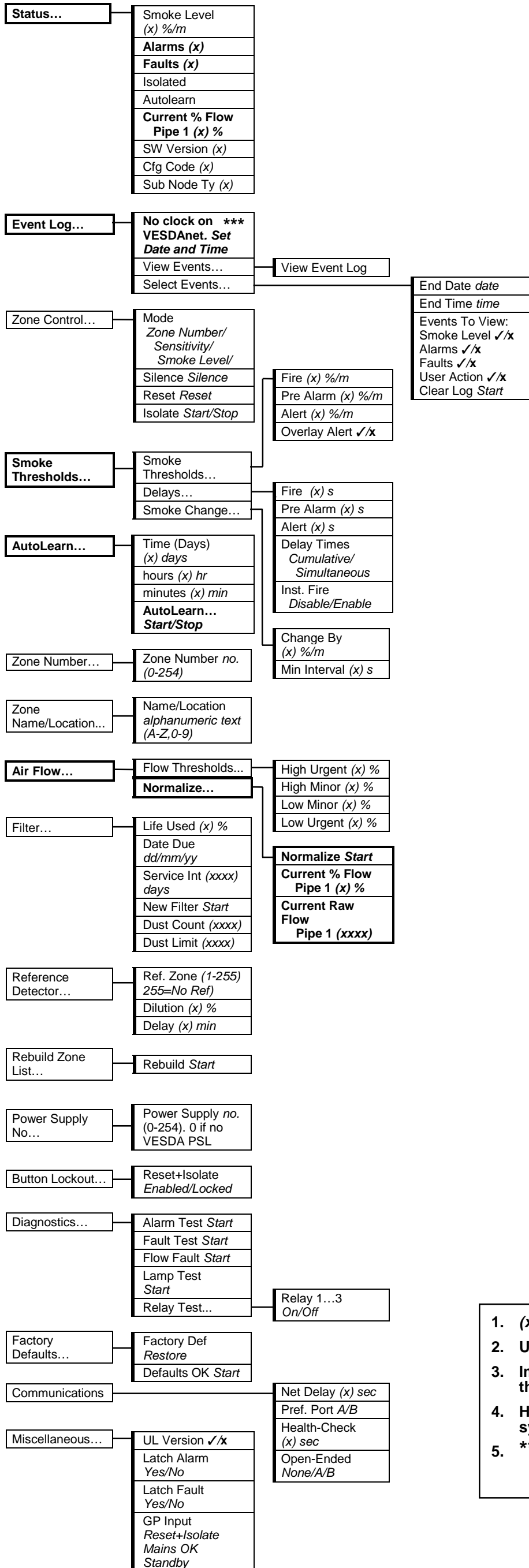

Menu Tree 2 – Display/Relays

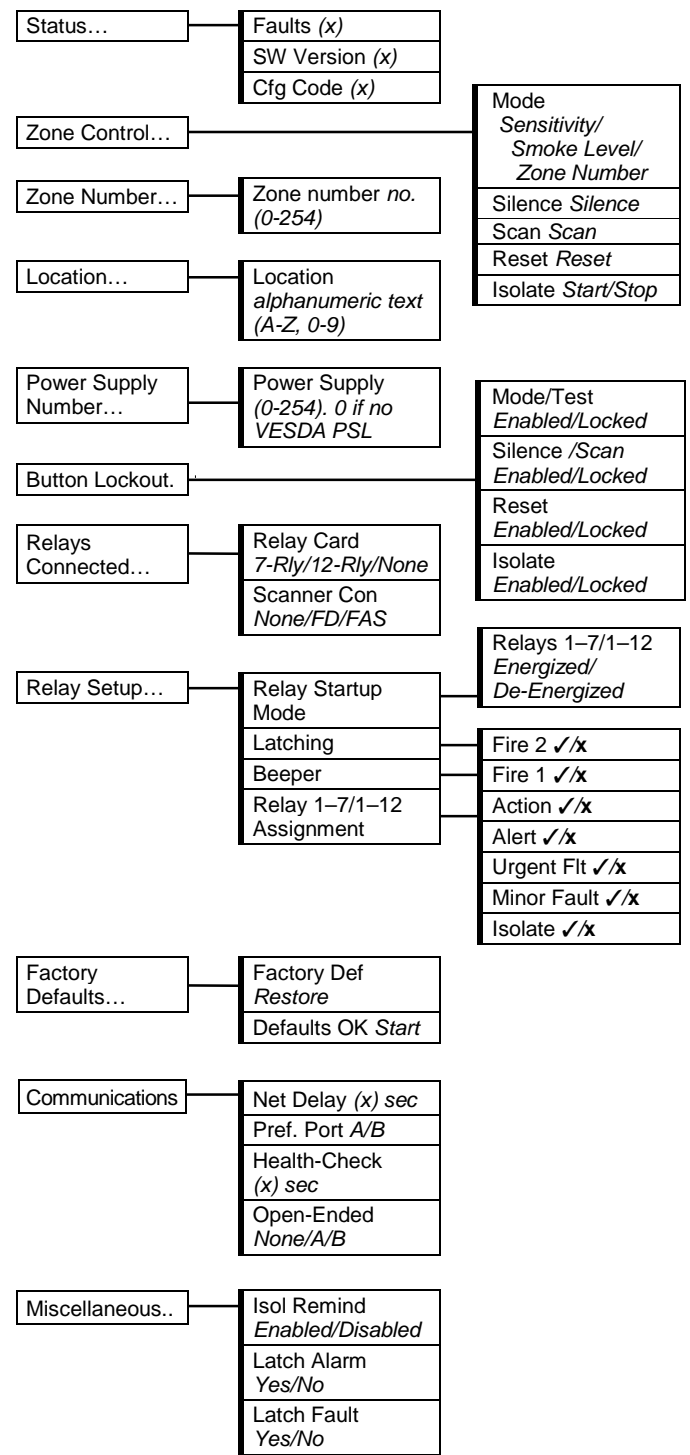

Menu Tree 3 – HLI

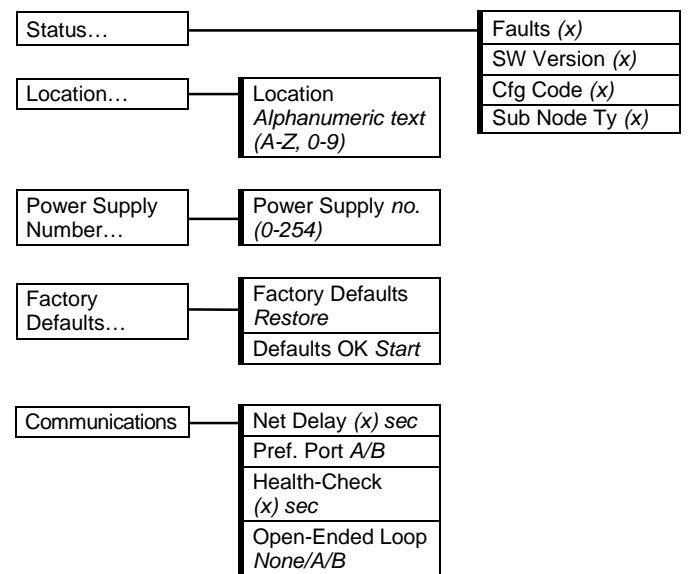

1. (x) = Numerical value shown on display.
2. Units of measure shown are in metric.
3. Imperial units of measure are displayed when US units are selected from the Miscellaneous menu. See Menu Tree 4.
4. Highlighted items are the minimum requirements to enable successful system operation.
5. *** Appears only on initial power up for the first time.

Menu Tree 4 - System/All Devices

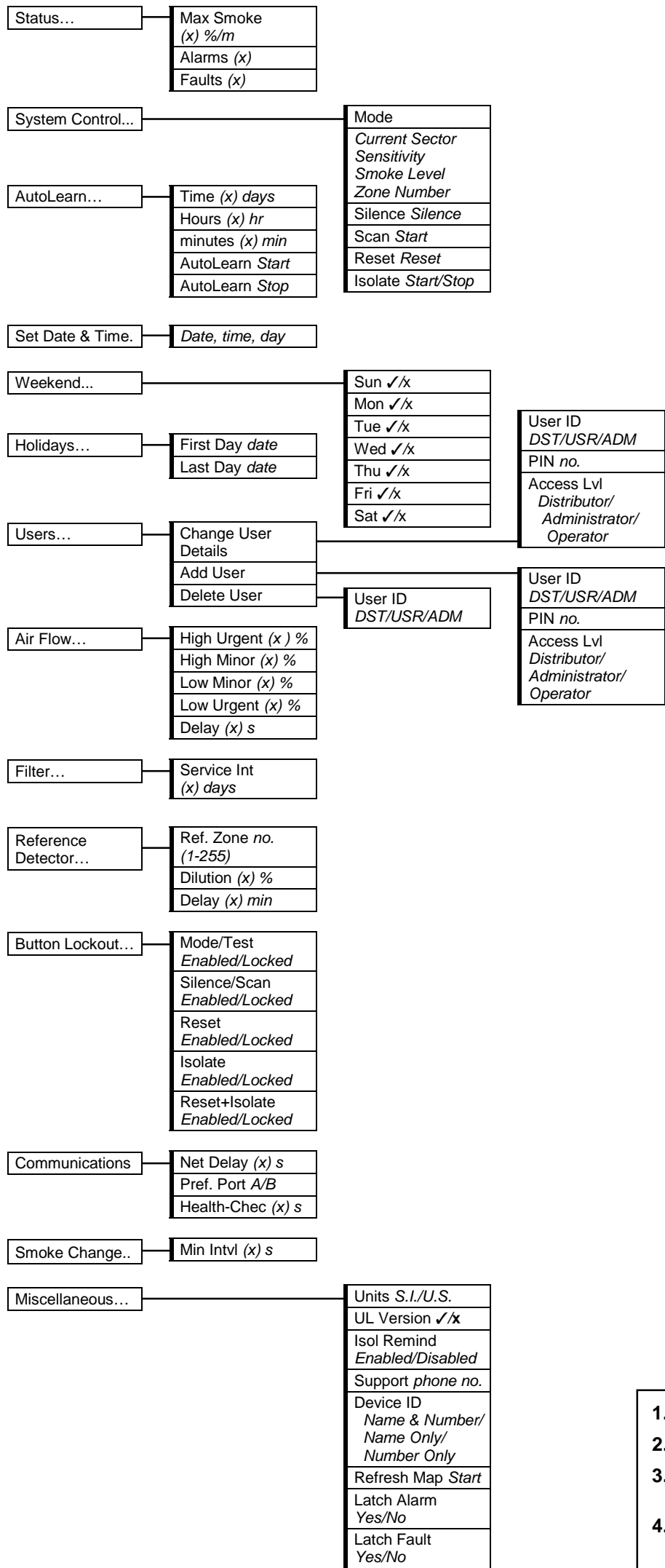

Menu Tree 5 - Programmer

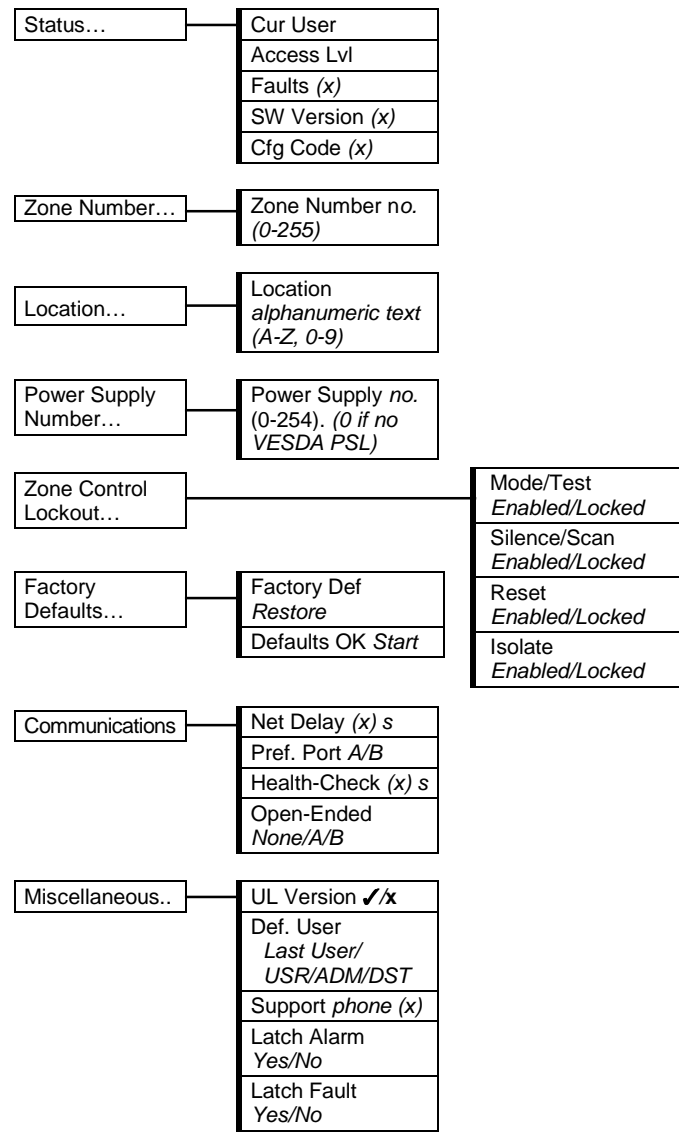

1. (x) = Numerical value shown on display.
2. Units of measure shown are in metric.
3. Imperial units of measure are displayed when US unit is selected from the Miscellaneous menu. See Menu Tree 4.
4. Highlighted items are the minimum requirements to enable successful system operation.



Australia and Asia

Vision Fire & Security
495 Blackburn Road
Mount Waverley, VIC, 3149
Australia
Ph +61 3 9211 7200
Fax +61 3 9211 7201
Free Call 1 800 700 203

The Americas

Vision Fire & Security
35 Pond Park Road
Hingham, MA 02043, USA
Ph +781 740 2223
Toll Free 800 229 4434
Fax +781 740 4433

Europe and the Middle East

Vision Fire & Security
Vision House, Focus 31 Mark Road
Hemel Hempstead
Herts, HP2 7BW UK
Ph +44 1442 242 330
Fax +441442 249 327

www.vesda.com