

**SSF-PROBE-DNR & SSF-PROBE-DNRW
Intelligent Duct Smoke Detector**



SSF-PROBE-DNR



SSF-PROBE-DNRW (watertight version)

Features:

- Photoelectric, integrated low-flow technology
- Air velocity rating from 0.5 m/s to 20.32 m/s
- Versatile mounting options: square or rectangular configuration
- Interchangeable standard detectors
- Broad ranges for operating temperature (-20°C to 70°C) and humidity (0% to 95% non-condensing)
- Patented sampling tube installs from front or back of the detector with no tools required
- Cover tamper signal
- Increased wiring space with a newly added 20mm conduit knockout
- Clear cover for convenient visual inspection
- Remote testing capability
- Requires an SSF-P to be fitted
- Accommodates the installation of an addressable relay module, sold separately, (FRM-1) for applications requiring a form-C relay

Description:

The SSF-PROBE-DNR intelligent non-relay photo-electric duct smoke detector feature a pivoting housing that fits both square and rectangular footprints capable of mounting to a round or rectangular duct.

SSF-PROBE-DNRW duct smoke detector, with its IP66 rating, is listed as a watertight enclosure providing protection against falling dirt, rain, and windblown dust, splashing and hose directed water, allowing operators to use the detector in the most extreme environments.

These units sense smoke in the most challenging conditions, operating in airflow speeds of 0.5 to 20.32 metres per second, temperatures of -20°C to 70°C, and a humidity range of 0% to 95% (non-condensing).

An improved cover design isolates the sensor head, which allows for ease of maintenance. A cover tamper feature indicates a trouble signal for a removed or improperly installed sensor cover. The housing provides a 20 mm conduit knockout and ample space to facilitate easy wiring and mounting of a relay module.

Specifications:

Dimensions:	Rectangular	37cmL x 12.7cmW x 6.4cmD
	Square	19.7cmL x 22.9cmW x 6.4cmD
Environmental Rating:		IP66 (SSF-PROBE-DNRW Only)
Operating Temperature Range:		-20°C to 70°C
Operating Humidity Range:		0% to 95% relative (Non-condensing)
Air Duct Velocity:		0.5 to 20.32 m/s
Weight:		0.73kg

Distributors For:



Unit 6
16 Lexington Drive
Bella Vista NSW 2153
Australia

PO Box 7026
Baulkham Hills BC
NSW 2153
Australia

tel 02 8850 2888
fax 02 8850 2999
www.firesense.com.au

Component Diagram:

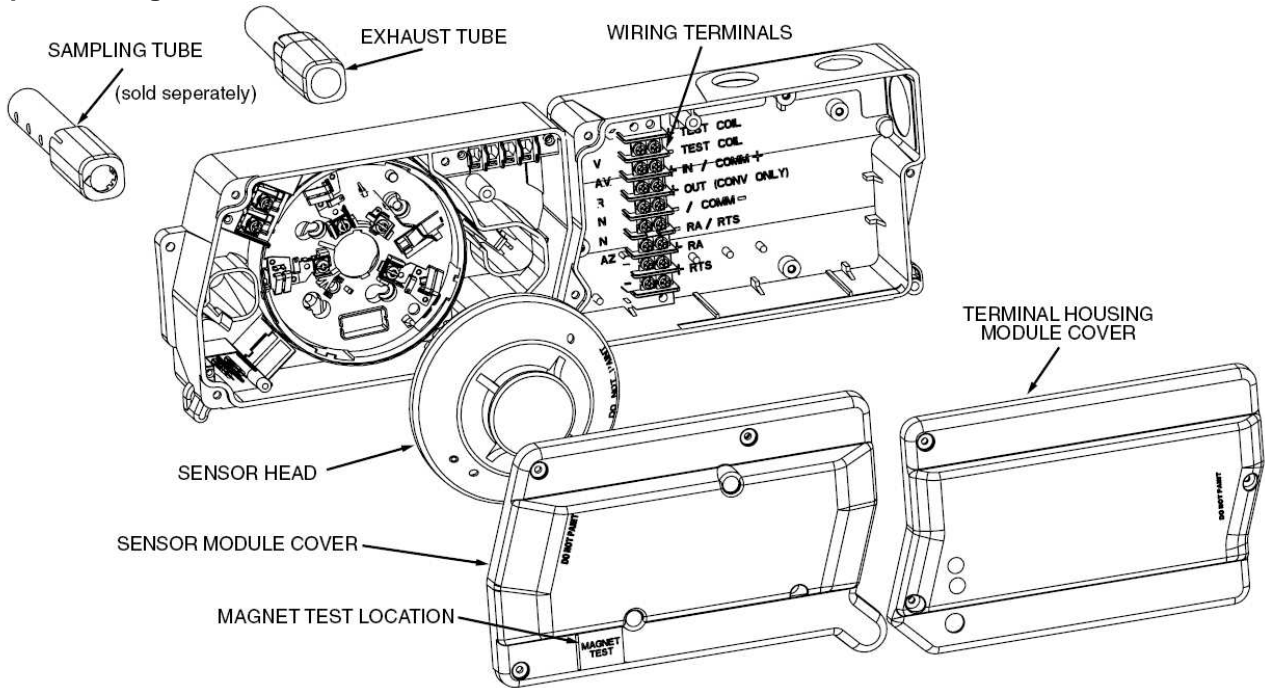

Connection Diagram:

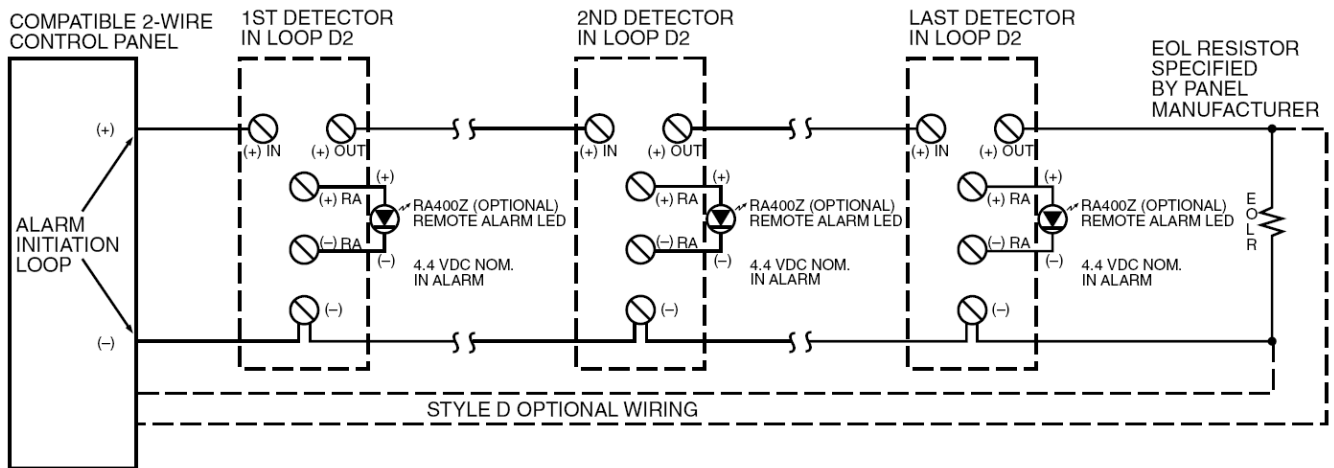

Accessories:

SS-DST3	Duct detector sampling tube to suit duct 0.5m to 1.2m
SS-DST5	Duct detector sampling tube to suit duct 1.2m to 2.4m
SS-DST10	Duct detector sampling tube to suit duct 2.4m to 3.7m



Approvals:

ActivFire Listing No.	afp 1998
-----------------------	----------

Distributors For:



Unit 6
16 Lexington Drive
Bella Vista NSW 2153
Australia

PO Box 7026
Baulkham Hills BC
NSW 2153
Australia

tel 02 8850 2888
fax 02 8850 2999
www.firesense.com.au